

### 产品特点:

- ✓ 小体积 127\*125\*40mm
- ✓ 高可靠性
- ✓ 使用 TS-35/7.5 或 TS-35/15 安装, 便于生产维护
- ✓ 效率 92%以上, 低损耗
- ✓ 并联冗余功能 (可选)
- ✓ 150%的峰值带载能力
- ✓ 内置 DC OK 和远程隔离信号输出
- ✓ 符合环保要求 RoHs6

### Features:

- ✓ Small size 127 \* 125 \* 40mm
- ✓ High Reliability
- ✓ Use TS-35/7.5 or TS-35/15 for easy production and maintenance
- ✓ 92% efficiency, low loss
- ✓ parallel redundancy (optional)
- ✓ 150% peak load capacity
- ✓ Built-in DC OK and remote isolated signal output
- ✓ Comply with RoHs6

### 应用领域:

- ✓ 工业控制
- ✓ 清洁能源
- ✓ 轨道交通
- ✓ 生产制造
- ✓ 对尺寸大小、环境要求十分严酷的场合
- ✓ 对寿命、可靠性要求很高的供配电系统

### Application:

- ✓ Industrial control
- ✓ Clean energy
- ✓ Track and traffic
- ✓ Production and Manufacturing
- ✓ It is very harsh on the size and use environment
- ✓ System with high requirements for lifetime and reliability

# EDF-T240-24

## 产品规格书

## PRODUCT SPECIFICATION

制造安全产品 驱动绿色世界 Power a Safe and Green world

Excellent 卓越 Creative 创造 United 协作



合肥华耀电子工业有限公司  
ECU ELECTRONICS INDUSTRIAL CO.,LTD.



微信扫码关注

电话 TEL 4006659997/0551-62731110  
传真 FAX+86-551-65324417 转 0

安徽省合肥市高新区天智路 41 号  
No.41 TianZhi road P.O BOX 9023-  
20,Hefei China

<http://www.ecu.com.cn>  
<http://www.ecupowersupply.com>  
[sales@ecu.com.cn](mailto:sales@ecu.com.cn)

## 订购信息 Ordering Information:

设计号 Design NO:

ECU2.932.13399

物料号 Part No:

6.13.70.1453

客户签章

Customer's signature:

日期 DATE:

基本参数 Basic Parameter	_____	1
输入特性 (输入 1): Input Characteristics (Input1):	_____	1
输出特性 (输出 1): Output Characteristics(Output1):	_____	2
环境特性 Environment Characteristics	_____	2
保护功能 Protection Function	_____	3
特殊功能 Signals Function	_____	3
电气安全 Electrical Safety	_____	3
电磁兼容 Electromagnetic Compatibility	_____	4
可靠性数据 Reliability	_____	5
结构与安装 Mechanical Installation	_____	5
框架图 Block diagram	_____	错误!未定义书签。
附件 (安装示意图、降额曲线、典型应用、导轨安装方法)	_____	7
Appendix(Product assembly/Derating curve/Typical application/Din track mounting)	_____	7

## 版本更改记录 Revisions

版本 Rev	日期 Date	更改说明 Description	核准 Approved
A00	2024-6-10	第一次发行 First Issue	陈虎

设计 Designed

李亮

审核 Checked

王金明

批准 Approved

陈虎

## 基本参数 Basic Parameter

项目 Item	单位 UNIT	规格 Specification	备注 Notes
产品输入输出类型 Input and output type		A+D	A) AC-DC; B) AC-AC; C) DC-AC; D) DC-DC;
产品工作原理类属 Working principle		A	A) 开关电源; B) 线性电源 A) Switching power supply; B) Linear power supply
输出电压 Output Voltage	V	24	
额定功率 Total Rated Power	W	240	
峰值功率 Total Peak Power	W	320	5 seconds
效率 Efficiency	%	92	400Vac/50Hz, 额定负载, 0.5h后测试; Run the test after 0.5 hours at Full Load;
功率因数校正 Power factor correction		C	A) 主动式 active PFC; B) 被动式 Passive PFC; C) 无 No
纹波&噪声 Ripple Noise	mVp-p	100	详见备注 See the note
产品认证标志 Industry and regional certification mark		1、6	0 无、1 CE、2 CCC、3 CQC、4 TUV、5 UL、6 CB、7 TUVul、8 CSA、9 FCC、10 KC、11 GL、12 ATEX、13 IECEx、14 CUL、15 其它

1. 输出纹波噪声测试条件/DC output ripple & noise test conditions:

- 示波器须设置在 20M 赫兹带宽/Oscilloscope should be limited at 20MHZ bandwidth;
- 将 0.1uF 的陶瓷电容和 47uF 的电解电容并联在线材末端/ Connect 0.1uF ceramic capacitors and 47uF electrolytic capacitors in parallel at the end of the wire;
- 使用 300mm 的双绞线连接电源和负载/ Connect the load and power supply with a 300mm twisted pair;
- 在负载端进行测试/ Testing is done on the load port;
- 若无特殊说明, 以上规格参数均在输入电压范围为 320~575Vac, 温度范围 25°C 的环境下测量。/ Unless otherwise specified, the above specifications are measured in the input voltage range of 320~575Vac and the temperature range of 25 ° C.2. " / ": 不符合项 " / ": No function;

## 输入特性: Input Characteristics:

项目 Item	单位 UNIT	最小值 MIN	额定值 Rated	最大值 Max	备注 Notes
输入电压类型 Power supply type			A+C+D		A) 三相供电; B) 单相供电; C) 双相供电; D) 直流供电; E) 其它不规则供电 A) Three-phase; B) Single-phase; C) Dual phase; D) DC power supply; E) Other power supply
输入电压 Input Voltage	Vac	320	400	575	两相 2-Phase 参考输出降额曲线 Refer to output derating curve.
	Vac	360	400	575	
	Vdc	450	/	800	
输入频率 Input Frequency	Hz	47	50	63	
输入电流 Input Current	A			1	400Vac, 满载 Full load.
				0.8	500Vac, 满载 Full Load.
输入冲击电流 Inrush Current	A			30	400Vac, 满载, 冷机启动 Full Load. cold start.
输入冲击电流方案 Inrush Current mode			B		A) 主动式 active; B) 被动式 Passive; C) 单电阻 Only Resistance; D) 无 NO
功率因数 Power Factor	/	0.55	/	/	400Vac, 满载 Full Load.
		0.5			500Vac, 满载 Full Load.
空载损耗 No-load loss	W			5	400Vac, 空载 No Load @ Vout=24V

输入保险 Input Fuse	3*T4A/500Vac
--------------------	--------------

"/": 不符合项 "/" : No function;

## 输出特性: Output Characteristics:

项目 Item	单位 Unit	最小值 Min	典型值 Typ	最大值 Max	备注 Notes
标准输出电压 Output Voltage	Vdc		24		
输出电压可调范围 Adjustable range	Vdc	23		28.5	
额定输出电流 Rated current	A	0		10	24V输出Output@24V
峰值输出电流1 Output Peak Current1	A			11	参考降额曲线Ref to derating curve
峰值输出电流2 Output Peak Current2	A			15	24V输出Output@24V
峰值功率持续时间1 Peak Power duration1	s	/	/	/	参考降额曲线Ref to derating curve
峰值电流持续时间2 Peak Current duration2	s			5	5秒后, 电源将进入恒流模式, 详见峰值功率图及限流特性图 The power supply will enter constant current mode after 5 Seconds; see peak current figure and current limiting characteristic for details
负载调整率 Load Regulation	/	/	/	+/-1	400Vac 0% load ~ 100% load最小负载到额定负载
输入电压调整率 Line Regulation	%			+/-0.5	320Vac~575Vac 100% load 额定负载
温度调整率 Temperature Regulation	%			+/-0.07	+/-0.07% @ 0°C~+60°C; +/-1% @ -25°C~0°C&+60°C~+70°C; +/-2.5% @ -40°C~-25°C;
电压误差 Voltage Tolerance	%			+/-2	-25°C~+70°C
开机延迟时间 Setup Time	s			2	400Vac 100% Load 额定负载
上升时间 Rise Time	ms			200	输出从10%上升到90%的时间 The output voltages shall rise from 10% to 90% of their output voltage.
保持时间 Hold time	ms	20			400Vac, 满载Full Load.
	ms	20			500Vac, 满载Full Load.
过冲响应 Overshoot &undershoot Response	%			+/-5	开关机时 Power on/off
负载动态 Load dynamic response	%			+/-5	设定周期20ms,升降电流0.1A/us,在10%~90%负载Settling time 20ms R/s 0.1A/us load 10%~90% load
串联 Connection in Series	V				详见附件 See Appendix
并联冗余功能 Parallel Connection	A				详见附件 See Appendix

"/": 不符合项 "/" : No function;

## 环境特性 Environment Characteristics

项目 ITEM	单位 UNIT	最小值 MIN	典型值 Rated	最大值MAX	备注 Notes
温度 Temperature	°C	-25	25	70	工作温度Operation Temperature; 55°C~70°C以上需降额使用, 参考降额曲线; -40°C启动;

					55°C~70°C Refer to derating curve; -40°C start up
		-40	25	85	贮藏温度Storage Temperature
相对湿度 Humidity	%	5%	RH	95%	工作湿度Operation Humidity
		5%	RH	95%	贮藏湿度Storage Humidity
振动 Vibration		幅度<15Hz, ±2mm (IEC 60068-2-6) /15Hz...150Hz, 2.3g, 90分钟 < 15Hz, amplitude ±2.5mm(acc. to IEC 60068-2-6) / 15Hz ... 150Hz,2.3g, 90 min.			
冲击 Impact		30g, 各个方向 (IEC 60068-2-27) 30g, each direction(acc. to IEC 60068-2-27)			
海拔高度 Altitude	m	≤3000m, 3000m以上降额使用, 15%load/Km, 最高海拔5000m ≤3000m, derated over 3000m, 15% load/Km, max altitude 5000m			
冷却方式 Cooling Mode		空气自然冷却 Air Cooling			
防护等级 IP level		IP20			
污染等级 Pollution level		PD2			
RoHS环境指令		符合Compliant			
阻燃等级 (外壳) Flame retardant rating		UL94V-0			
船级社 DNV GL		/			

"/": 不符合项 "/" : No function;

## 保护功能 Protection Function

项目 Item	技术要求 Requirement	恢复方式 Recovery mode	保护方式 Protection mode	注释 Notes
输出短路保护 Output Short Circuit Protection	短路保护时间大于等于60秒/Short Circuit Protection time is above of 60s.电源无损坏, 关闭输出电压 No damage shut down O/P voltage	A	B	恢复方式Recovery mode: A) 自动恢复Auto Recovers; B) 重启恢复Restart;
输出过流保护 Output Over current Protection	155%~170% @ Io	A	B	
输出过压保护 Output Over voltage Protection	120%~170% @ Vo	A	C	保护方式Protection mode: A) 恒功率Constant power; B) 恒电流Constant current; C) 输出掉电 Output voltage drop;
过温保护 Over Temperature Protection	关闭输出电压 Shut down O/P voltage.	A	C	

"/": 不符合项 "/" : No function;

## 特殊功能 Signals Function

项目 Item	技术要求 Requirement
面板显示 Panel display	当输出指标正常时, 绿色LED常亮/Output voltage≥21.6V, Green LED is always on;
远程信号 Remote signal	与输出隔离, 常开触点; 当输出电压大于85%时, DC OK为低阻抗≤50mΩ, 最大耐受直流30 V / 1 A/ Normally open contact, isolated output,; Output voltage≥85%V, DC OK is a low impedance ≤ 50mΩ, Max DC 30 V / 1 A

"/": 不符合项 "/" : No function;

## 电气安全 Electrical Safety

项目	测试方法	测试条件
----	------	------

Item	Test Method	Test Conditions
高压测试 Hi-pot Test	输入-输出 I/P-O/P	4242Vdc. 60s, ≤1mA
	输入-大地 I/P-PE	2121Vdc. 60s, ≤1mA
	输出-大地 O/P-PE	700Vdc. 60s, ≤1mA
绝缘阻抗 Withstand Resistance	输入-输出 I/P-O/P	500VDC. ≥ 5MΩ
	输入-大地 I/P-PE	500VDC. ≥ 5MΩ
	输出-大地 O/P-PE	500VDC. ≥ 5MΩ
泄露电流 Leakage Current	L1、L2、L3-外壳/L1、L2、L3-Case	3.5mA Max
	L1、L2、L3-PE/L1、L2、L3-PE	3.5mA Max
接地阻抗 PE Resistance	PE-外壳/PE-Case	< 0.1Ohm
过电压等级 Overvoltage category	III, II	III (IEC 61010-1, IEC 61010-2-201, EN 62368-1, EN 61558-2-16) II (EN 62368-1, EN 60335-1)
电气设备安全等级类别 Electrical equipment safety class	A	A)一类设备Class I ;B)二类设备Class II ;C)三类设备 (最高标称电压不超过50Vac或120VDC, 以及不属于AB) Class III; EN 61140, GB/T17045
安规标准 Safety	/	UL1310 (CLASS II产品)
	/	EN62368-1, GB4943.1资讯类
	/	EN60601-1, GB9706.1医疗类
	/	EN61347-1, EN61347-2-13, GB7000.1, GB19510.1, GB 19510.14 灯具类
	/	EN60335-1, EN60335-2-29, GB4706.1 家电类
	/	EN61010, GB4793.1工控类

1) “/”: 不符合项 “/”Non-conformance;

## 电磁兼容 Electromagnetic Compatibility

项目 Item	测试方法 Test Method	测试条件 Test Conditions
静电ESD Electrostatic Discharge	IEC 61000-4-2 GB17626-2	Criteria A; Air Discharge: ±8kV; Contact Discharge: ±4kV
射频辐射RS Radiated Field	IEC 61000-4-3 GB17626-3	Criteria A; 80-1000MHz, 10V/M, 80% modulation (1kHz);
脉冲杂讯EFT Electrical Fast Transient / Burst	IEC 61000-4-4 GB17626-4	Criteria A; ±4kV
雷击 Surge	IEC 61000-4-5 GB17626-5	Criteria A; Common Mode: 4kV; Differential Mode: 2kV
射频传导 Conducted Emission	IEC 61000-4-6 GB17626-6	Criteria A; 0.15-80MHz, 10Vrms, 80% modulation (1kHz) 80MHz-1GHz, 10Vrms, 80% modulation (1kHz) 1.4GHz-2GHz, 10Vrms, 80% modulation (1kHz) 2GHz-2.7GHz, 10Vrms, 80% modulation (1kHz)
电源磁场 Power Frequency Magnetic Fields	IEC 61000-4-8 GB17626-8	30A/meter, Criteria B
脉冲磁场抗扰度试验 Impulse Magnetic Field Immunity Test	IEC 61000-4-9 GB17626-9	300A/meter, Criteria B
阻尼振荡磁场抗扰度试验 Damped Oscillatory Magnetic Field Immunity Test	IEC 61000-4-10 GB17626-10	100A/meter 100KHz and 100MHz, Criteria B
电压瞬断 Voltage Dips And Interruptions	IEC 61000-4-11 GB17626-11	Voltage Dips >95% reduction, 0.5 period Criteria A
		Voltage Dips >30% reduction, 25 period Criteria B

		Voltage interruptions >95% reduction,250 period	Criteria B
低能量脉冲 Low Energy Pulse Test (Ring Wave)	IEC 61000-4-12 GB17626-12	Criteria B Common Mode:2kV; Differential Mode: 1kV	
谐波 Harmonic Current Emission	IEC/EN 61000-3-2 GB17625-1	Class A	
电磁耐受标准 Immunity Generic Standards	/	EN 55024,GB17618 资讯类 Information technology	
	/	EN55014-2 家电类 Household appliances	
	/	EN60601-1-2 医疗类 Medical	
	/	EN61547 灯具类 Lamps	
		EN61000-6-1,EN50082-1,GB/T17799-1 轻工业环境 Light industry environment	
传导和辐射通用标准 CE&RE		EN 61000-6-2,EN55082-2,GB/T17799-2 工业环境 Industry environment	
	/	GB9254, CISPR 32, EN 55032 : Class B 资讯类 Information technology	
	/	GB4824, CISPR 11, EN 55011 : Class B 医疗类 Medical	
	/	GB17743, EN55015, CISPR15: Class B 灯具类 Lamps	
		GB4343-1, CISPR14, EN55014-1: Class B 家电类 Household appliances	
	EN 61000-6-3, FCC Title 47, EN55011: Class B 工控类 Industrial control		
电压波动和闪烁 Voltage Fluctuation and Flicker		IEC/EN 61000-3-3, GB17625.2; Criteria B	

- 1) 标准A: 规格界限内正常性能 Criteria A: Normal performance within the specification limits;
- 2) 标准B: 可自行恢复的临时性退化或功能丧失 Criteria B: Temporary degradation or loss of function which is self-recoverable;
- 3) 标准C: 不可自行恢复的临时性退化或功能丧失, 必须重新启动后才能恢复正常工作 Criteria C: Need to restart the power supply, to return to normal work;
- 4) 标准D: 永久性退化或功能丧失, 需要更换零部件或维修人员介入 Criteria D: Permanent degeneration or loss of function;
- 5) 不对称: 共模 (线对地) Asymmetrical: Common mode (Line to earth);
- 6) 对称: 差模 (线对线) Symmetrical: Differential mode (Line to line);
- 7) “/”: 不符合项 “/” Non-conformance;
- 8) 电源应视为系统内元件的一部分, 需结合终端设备进行EMC确认 Power should be considered part of the element within the system, to be combined with the terminal device EMC acknowledgment;

## 可靠性数据 Reliability

项目 Item	数据 Data	测试条件 Test Conditions
产品老化 Burn-in	100%	400Vac, 满载, 40°C±5°C, 4小时
平均无故障时间 MTBF	200000H Min	400Vac, 满载, 25°C, MIL HDBK 217F

“/”: 不符合项 “/” Non-conformance;

## 结构与安装 Mechanical Installation

项目 Item	数据 Data	备注 Note
尺寸mm (长宽高) Size	127 * 125* 40	材质: 铝; Housing : AL
重量Kg Weight	0.65	
安装方式 Installation	导轨式安装 mounted on 35mm DIN rails	TS-35/7.5或TS-35/15
最小间距 Space	上下(above/below): 45mm; 左右(left and right side): 0mm,5mm with a heat source	

输入端子 Input Terminal	脚距10.0mm, 4位/Pitch=10.0mm, 4pin	直插式连接Push-In Terminal;
	1 PIN---FG	硬导线横截面Hard wire cross section 0.2 mm <sup>2</sup> ... 4 mm <sup>2</sup> ;
	2PIN---L3	柔性导线横截面Flexible wire cross section 0.2 mm <sup>2</sup> ... 2.5 mm <sup>2</sup>
	3PIN---L2	横截面Cross section AWG 24 ... 12
	4PIN---L1	剥线长度Strip length 10 mm
输出端子 Output Terminal	脚距5.0mm, 4位/Pitch=5.0mm, 4pin	直插式连接Push-In Terminal;
	1 PIN---V-	硬导线横截面Hard/Flexible wire cross section 0.2 mm <sup>2</sup> ... 6 mm <sup>2</sup>
	2 PIN---V-	横截面Cross section AWG 24 ... 8
	3 PIN---V+	剥线长度Strip length 14mm-15 mm
	4 PIN---V+	
输出DC OK端子 Output DC OK Terminal	脚距5.0mm, 2位/Pitch=5.0mm, 2pin	直插式连接Push-In Terminal;
	5 PIN---DC OK+	硬导线横截面Hard wire cross section 0.2 mm <sup>2</sup> ... 4 mm <sup>2</sup> ;
	6 PIN---DC OK-	柔性导线横截面Flexible wire cross section 0.2 mm <sup>2</sup> ... 2.5 mm <sup>2</sup> 横截面Cross section AWG 24 ... 12 剥线长度Strip length 10 mm



# 附件 (安装示意图、降额曲线、典型应用、导轨安装方法)

## Appendix(Product assembly/Derating curve/Typical application/Din track mounting)

### 1. 产品装配示意图 Product assembly

说明:

Note:

A: 产品名称特性示意, 具体参数依照规格书。

A: Refer to product specifications.

B: 建议扭矩:M3.0螺钉<0.4 N·m; M4.0螺钉<0.6 N·m。

B:Suggested tightening torque:M3.0 screw < 0.4 N·m;M4.0 screw < 0.6 N·m.

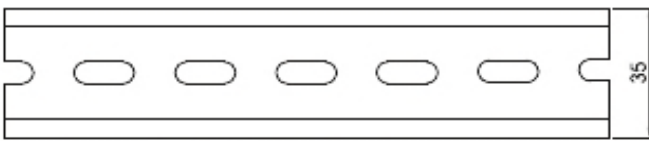

Install rail / 安装轨道: TS35/7.5 or TS35/15

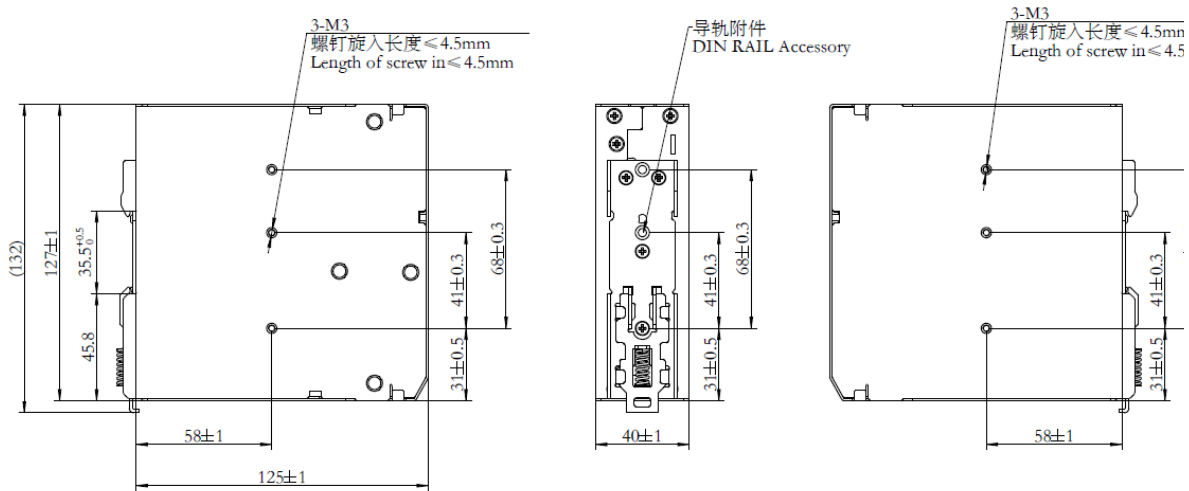

### 2. 降额曲线 Derating curve:



图1：环境温度和输入电压下输出功率降额曲线

Fig1: Output Power Derating curve depending on Ambient Temperature and Input Voltage

### 3. 限流特性 Current Limiting Characteristic

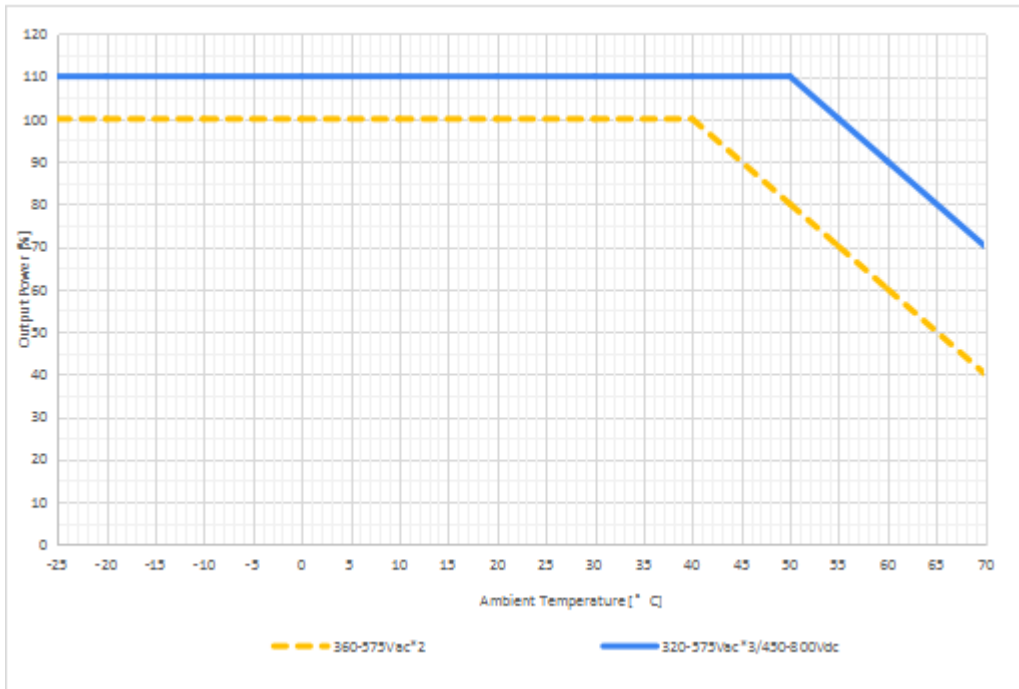

图1：正常输出电压下，正常和峰值工作时的限流曲线

Fig 1: Current limiting curve in normal and Boost operation depending on the nominal output voltage

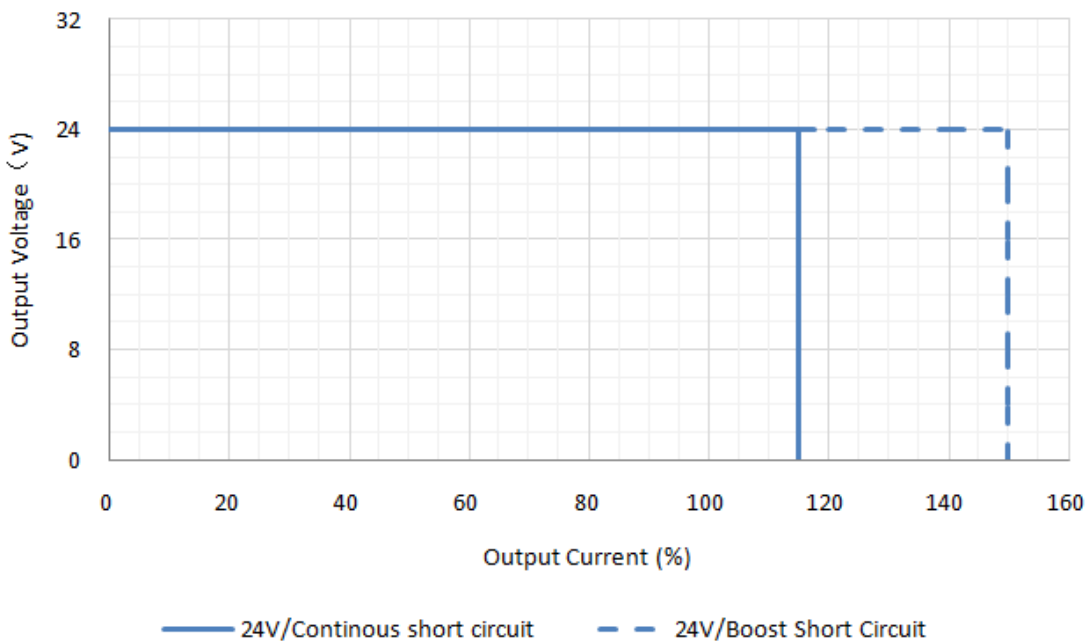

图2:短路情况下，非重复的峰值电流特性

Fig 2: Non-repetitive Boost during continuous short circuit

#### 4. 峰值功率特性 Boost Characteristic

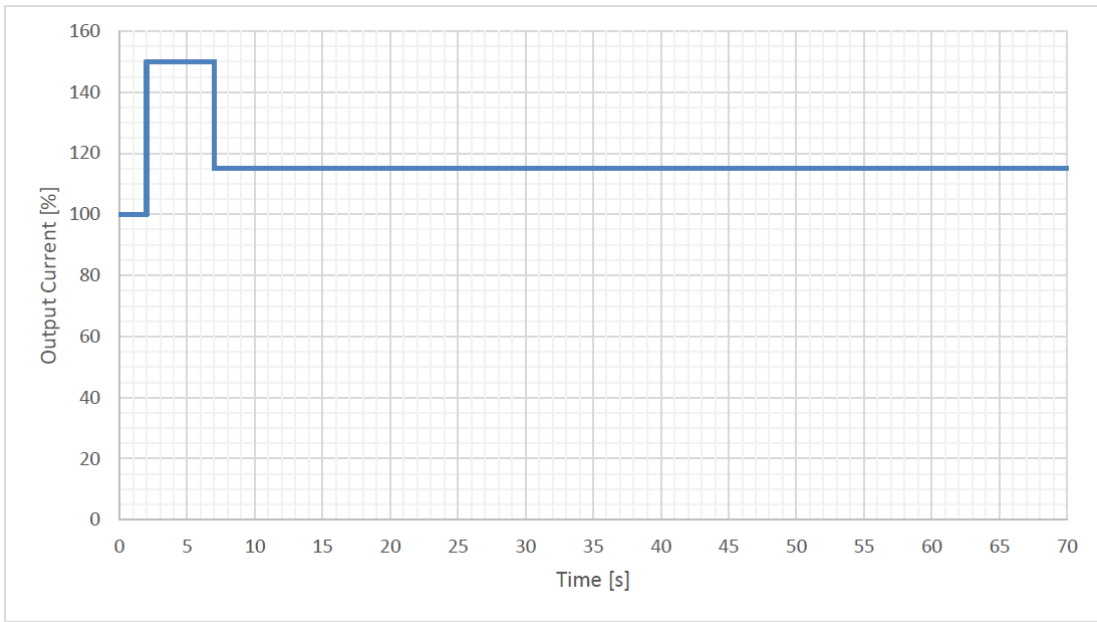

图1: 环温50°C情况下（80%→150%输出功率），峰值功率时间5s

Fig 1: Timing between two Boost events for 5s at 50°C ambient (80%→150% output power)

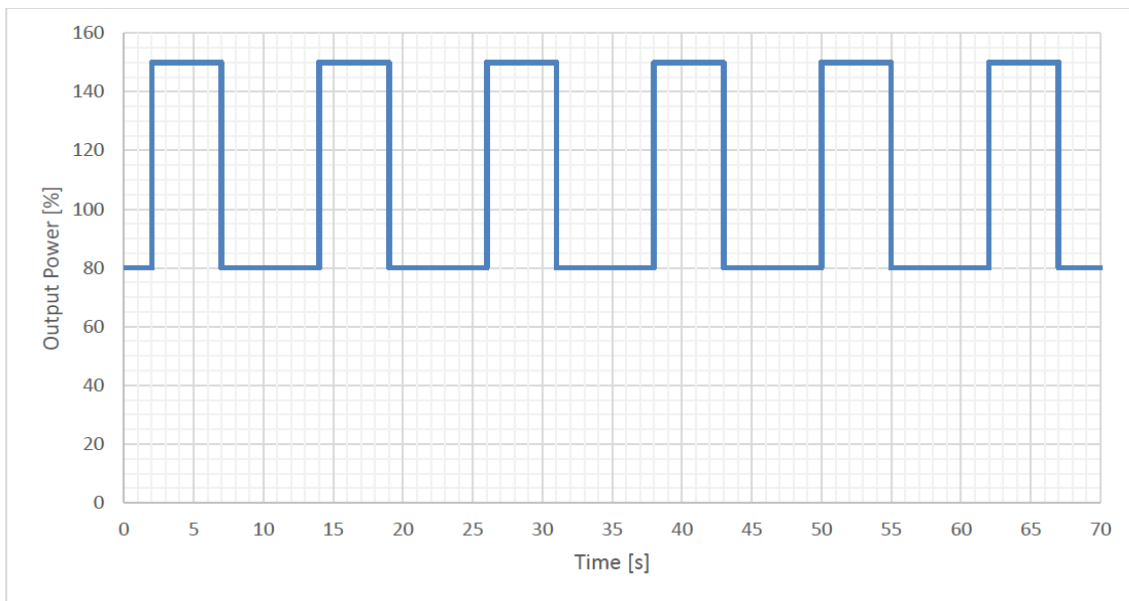

图2: 环温50°C情况下 (100%→150%输出功率), 峰值功率时间5s  
 Fig 2: Timing between two Boost events for 5s at 50°C ambient (100%→150% output power)

### 5. 典型应用 Typical application:

#### 3.1 串联接线图 Series Operation Connection Diagram:

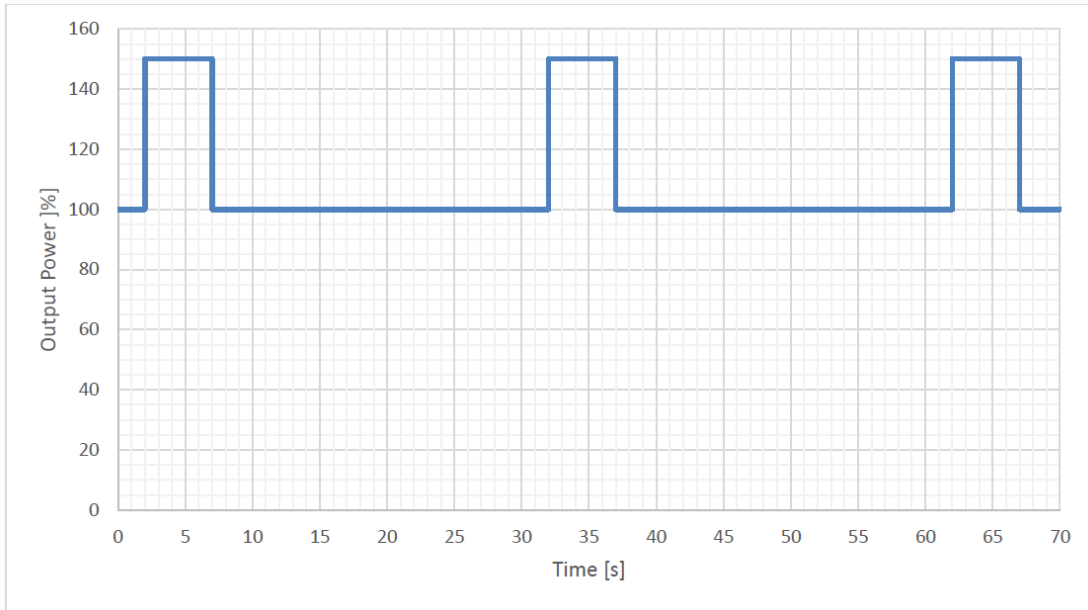
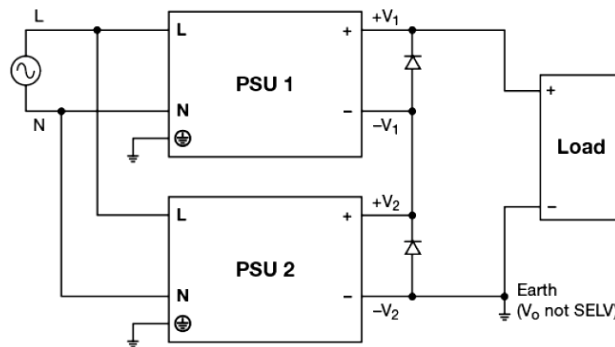

#### 3.2 1+1 冗余接线图 1+1 Redundancy Connection Diagram

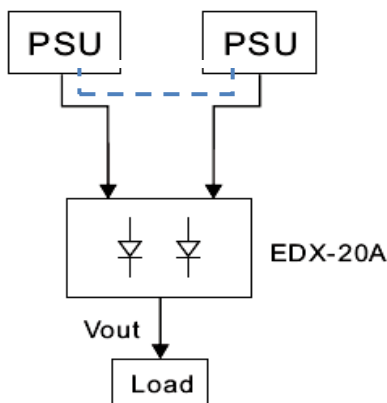

3.3 1+N 冗余接线图 1+N Redundancy Connection Diagram:

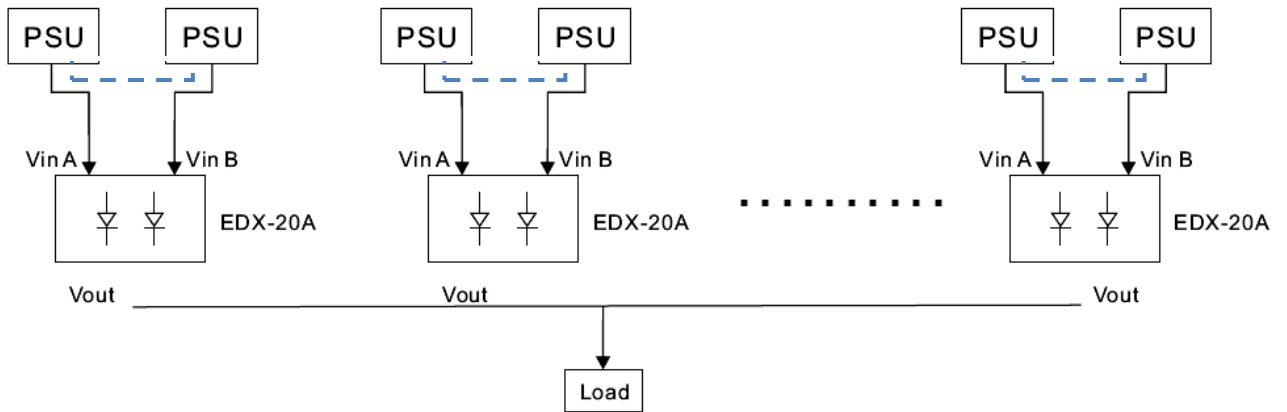

3.4 可靠性系统构建图 Reliability system:

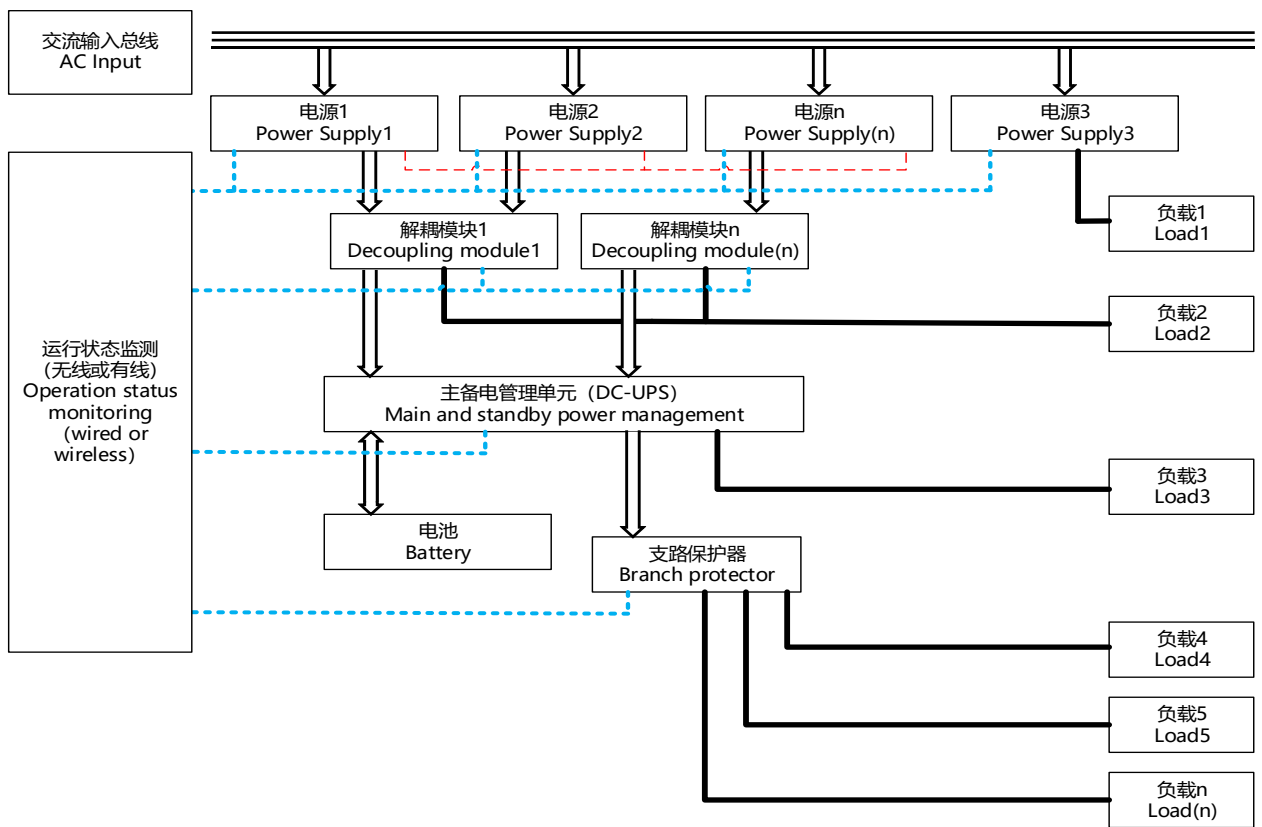

6. 导轨安装方法 Din track mounting:

- (1) To mount the Block on a DI track, hook portion (A) of the Block onto the track and press the Block in direction (B).
- 安装：将(A)部分挂入导轨，朝(B)方向按压卡入导轨

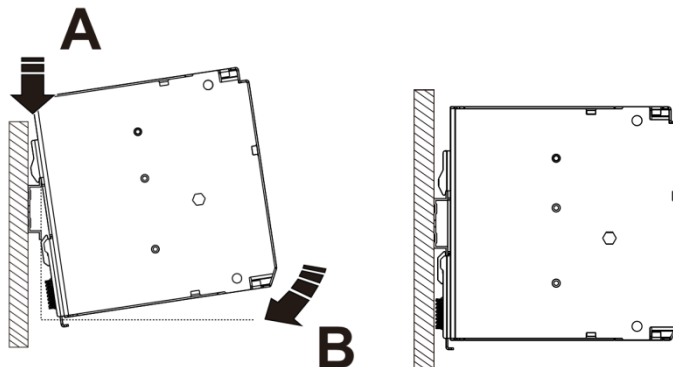

(2) To dismount the Block, pull down portion (C) with a flat-blade screw-driver and pull out the Block.

拆卸：用平口螺丝刀下拉 (C)部分拆卸电源

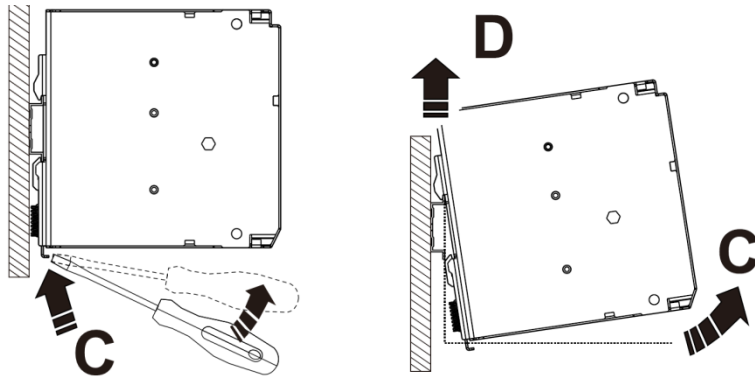

(3)通用壁挂式安装图 Mounting the universal wall adapter

