

产品特点:

- ✓ 小体积 127*125*40mm
- ✓ 高可靠性
- ✓ 使用 TS-35/7.5 或 TS-35/15 安装, 便于生产维护
- ✓ 效率 93%以上, 低损耗
- ✓ 9+1 并联冗余功能 (可选)
- ✓ 150%的峰值带载能力
- ✓ 内置主动式 PFC 功能, PF>0.9
- ✓ 内置 DC OK 和远程隔离信号输出
- ✓ 符合环保要求 RoHs6

Features:

- ✓ Small size 127 * 125 * 40mm
- ✓ High Reliability
- ✓ Use TS-35/7.5 or TS-35/15 for easy production and maintenance
- ✓ 93% efficiency, low loss
- ✓ 9 + 1 parallel redundancy (optional)
- ✓ 150% peak load capacity
- ✓ Built-in active PFC, PF> 0.9
- ✓ Built-in DC OK and remote isolated signal output
- ✓ Comply with RoHs6

应用领域:

- ✓ 工业控制
- ✓ 清洁能源
- ✓ 轨道交通
- ✓ 生产制造
- ✓ 对尺寸大小、环境要求十分严酷的场合
- ✓ 对寿命、可靠性要求很高的供配电系统

Application:

- ✓ Industrial control
- ✓ Clean energy
- ✓ Track and traffic
- ✓ Production and Manufacturing
- ✓ It is very harsh on the size and use environment
- ✓ System with high requirements for lifetime and reliability

EDF-240-24

产品规格书

PRODUCT SPECIFICATION

制造安全产品 驱动绿色世界 Power a Safe and Green world

Excellent 卓越 Creative 创造 United 协作



合肥华耀电子工业有限公司
ECU ELECTRONICS INDUSTRIAL CO.,LTD.



微信扫码关注

电话 TEL 4006659997/0551-62731110
传真 FAX+86-551-65324417 转 0

安徽省合肥市蜀山区淠河路 88 号
No.88 Pihe road P.O BOX 9023-
20,Hefei China

<http://www.ecu.com.cn>
<http://www.ecupowersupply.com>
sales@ecu.com.cn

订购信息 Ordering Information:

设计号 Design NO:

ECU2.932.11428

物料号 Part No:

5.13.70.0512

客户签章

Customer's signature:

日期 DATE:

基本参数 Basic Parameter _____	1
输入特性 (输入 1): Input Characteristics (Input1): _____	1
输出特性 (输出 1): Output Characteristics(Output1): _____	2
环境特性 Environment Characteristics _____	3
保护功能 Protection Function _____	3
特殊功能 Signals Function _____	4
电气安全 Electrical Safety _____	4
电磁兼容 Electromagnetic Compatibility _____	5
可靠性数据 Reliability _____	6
结构与安装 Mechanical Installation _____	7
框架图 Block diagram _____	7
附件 (安装示意图、降额曲线、典型应用、导轨安装方法) _____	9
Appendix(Product assembly/Derating curve/Typical application/Din track mounting) _____	9

版本更改记录 Revisions

版本 Rev	日期 Date	更改说明 Description	核准 Approved
A00	2021-4-10	第一次发行 First Issue	扶廷武
A01	2023-3-30	更新认证 Updated certificated	陈虎

设计 Designed

田 朗

审核 Checked

王金明

批准 Approved

陈 虎

基本参数 Basic Parameter

项目 Item	单位 UNIT	规格 Specification	备注 Notes
产品输入输出类型 Input and output type		A+D	A) AC-DC; B) AC-AC; C) DC-AC; D) DC-DC;
产品工作原理类属 Working principle		A	A) 开关电源; B) 线性电源 A) Switching power supply; B) Linear power supply
输出电压 Output Voltage	V	24	
额定功率 Total Rated Power	W	240	
峰值功率 Total Peak Power	W	360	5 seconds
效率 Efficiency	%	93	230Vac/50Hz, 额定负载, 0.5h后测试; Run the test after 0.5 hours at Full Load;
功率因数校正 Power factor correction		A	A) 主动式 active PFC; B) 被动式 Passive PFC; C) 无 No
纹波&噪声 Ripple Noise	mVp-p	120	详见备注 See the note
产品认证标志 Industry and regional certification mark		1、6	0 无、1 CE、2 CCC、3 CQC、4 TUV、5 UL、6 CB、7 TUVul、8 CSA、9 FCC、10 KC、11 GL、12 ATEX、13 IECEx、14 CUL、15 其它

1. 输出纹波噪声测试条件/DC output ripple & noise test conditions:

1) 示波器须设置在 20M 赫兹带宽/Oscilloscope should be limited at 20MHZ bandwidth;

2) 将 0.1uF 的陶瓷电容和 47uF 的电解电容并联在线材末端/ Connect 0.1uF ceramic capacitors and 47uF electrolytic capacitors in parallel at the end of the wire;

3) 使用 300mm 的双绞线连接电源和负载/ Connect the load and power supply with a 300mm twisted pair;

4) 在负载端进行测试/ Testing is done on the load port;

5) 若无特殊说明, 以上规格参数均在输入电压范围为 90~264Vac, 温度范围-20°C及以上的环境下测量; 当环境温度控制在-40°C~-20°C时, 纹波噪声将被控制在 1.0V 以内。/Without special instructions, the above specifications shall be measured in an environment with an input range of 90~264Vac and a temperature range of -20°C or above; when the ambient temperature is between -40°C and -20°C, ripple & noise will be controlled within 1.0V.

2. "/": 不符合项 "/" : No function;

输入特性 (输入 1) : Input Characteristics (Input1) :

项目 Item	单位 UNIT	最小值 MIN	额定值 Rated	最大值 Max	备注 Notes
输入电压类型 Power supply type			B+D		A) 三相供电; B) 单相供电; C) 双相供电; D) 直流供电; E) 其它不规则供电 A) Three-phase; B) Single-phase; C) Dual phase; D) DC power supply; E) Other power supply
输入电压 Input Voltage	Vac	85	115/230	264	参考输出降额曲线 Refer to output derating curve.
	Vdc	90	310	370	
输入频率 Input Frequency	Hz	47	50	63	
输入电流 Input Current	A			1.3	230Vac 满载 Full load
				3.8	115Vac, 满载 Full Load.
输入冲击电流 Inrush Current	A			20	115Vac, 满载, 冷机启动 Full Load. cold start.
				30	230Vac, 满载, 冷机启动 Full Load. cold start.
输入冲击电流方案 Inrush Current mode			B		A) 主动式 active; B) 被动式 Passive; C) 单电阻 Only Resistance; D) 无 NO
功率因数 Power Factor	/	0.95	/	/	115Vac, 满载 Full Load.
		0.90			230Vac, 满载 Full Load.

空载损耗 No-load loss	W			5	230Vac,空载No Load @ Vout=24V
输入保险 Input Fuse	T5A/250Vac				

"/": 不符合项 " / ": No function;

输出特性 (输出 1) : Output Characteristics(Output1):

项目 Item	单位 Unit	最小值 Min	典型值 Typ	最大值 Max	备注 Notes
标准输出电压 Output Voltage	Vdc		24		
输出电压可调范围 Adjustable range	Vdc	23		28.5	
额定输出电流 Rated current	A	0		10	24V输出Output@24V
峰值输出电流 Output Peak Current	A			15	24V输出Output@24V
峰值功率持续时间 Peak Power duration	s			5	5秒后, 电源将进入恒流模式, 详见峰值功率图及限流特性图 The power supply will enter constant current mode after 5 Seconds; see peak current figure and current limiting characteristic for details
峰值电流持续时间 Peak Current duration	s			5	5秒后, 电源将进入恒流模式, 详见峰值功率图及限流特性图 The power supply will enter constant current mode after 5 Seconds; see peak current figure and current limiting characteristic for details
负载调整率 Load Regulation	/	/	/	+/-1	230Vac 0% load ~ 100% load 最小负载到额定负载
输入电压调整率 Line Regulation	%			+/-0.5	100Vac~264Vac 100% load 额定负载
温度调整率 Temperature Regulation	%			+/-0.07	+/-0.07% @ 0°C~+60°C; +/-1% @ -25°C~0°C&+60°C~+70°C; +/-2.5% @ -40°C~-25°C;
电压误差 Voltage Tolerance	%			+/-2	-25°C~+70°C
开机延迟时间 Setup Time	s			2	115Vac&230Vac 100% Load 额定负载
上升时间 Rise Time	ms			100	输出从10%上升到90%的时间 The output voltages shall rise from 10% to 90% of their output voltage.
保持时间 Hold time	ms	20			115Vac, 满载Full Load.
	ms	20			230Vac, 满载Full Load.
过冲响应 Overshoot &undershoot Response	%			+/-5	开关机时 Power on/off
负载动态 Load dynamic response	%			+/-5	设定周期20ms,升降电流0.1A/us,在10%~90%负载Settling time 20ms R/s 0.1A/us load 10%~90% load
串联 Connection in Series	V			2	可以, 详见附件; YES
并联 (可选) Connection in Parallel	A			2	可以, 用于冗余和增加功率容量, 见附件; Yes, for redundancy and increased capacity

"/": 不符合项 " / ": No function;

环境特性 Environment Characteristics

项目 ITEM	单位 UNIT	最小值 MIN	典型值 Rated	最大值MAX	备注 Notes
温度 Temperature	°C	-25	25	70	工作温度Operation Temperature; 50°C~70°C以上需降额使用, 参考降额曲线; -40°C启动; 50°C~70°C Refer to derating curve; -40°C start up
		-40	25	85	贮藏温度Storage Temperature
相对湿度 Humidity	%	5%	RH	95%	工作湿度Operation Humidity
		5%	RH	95%	贮藏湿度Storage Humidity
振动 Vibration		<15Hz, 振幅±2.5mm, IEC 60068-2-6, 正弦15-150Hz, 2.3 G, X、Y、Z轴各90分钟; <15Hz, amplitude of ±2.5mm; Sine Wave: 15-150Hz, 2.3G, 90 min per axis for all X, Y, Z directions			
冲击 Impact		IEC60068-2-27, 半正弦波: 30G, 持续18ms, 每个方向3次, 共6次 Half Sine Wave: 30G for a duration of 18ms, 3 times per direction, 6 times in total			
海拔高度 Altitude	m	≤3000m, 3000m以上降额使用, 15%load/Km, 最高海拔5000m ≤3000m, For used above 3000m need be derated, 15%load/Km, 5000m maximum altitude.			
盐雾 Salt fog		IEC60068-2-11/GBT2423.17, 5% NaCl, 35°C±2°C, pH(6.5-7.2), 48H, 无明显变质和腐蚀(≤3mm ²)			
冷却方式 Cooling Mode		空气自然冷却 Air Cooling			
防护等级 IP level		IP20 (IEC60529)			
污染等级 Pollution level		PD2			
RoHS环境指令		符合Compliant			
阻燃等级 (外壳) Flame retardant rating		UL94V-0			
船级社 DNV GL		/			

“/”：不符合项 “/”：No function;

保护功能 Protection Function

项目 Item	技术要求 Requirement	恢复方式 Recovery mode	保护方式 Protection mode	注释 Notes
输出短路保护 Output Short Circuit Protection	短路保护时间大于等于60秒/Short Circuit Protection time is above of 60s. 电源无损坏, 关闭输出电压 No damage shut down O/P voltage	A	B	恢复方式Recovery mode: A) 自动恢复Auto Recovers; B) 重启恢复Restart;
输出过流保护 Output Over current Protection	160%~180% @ Io	A	B	
输出过压保护 Output Over voltage Protection	150~200% @ Vo	A	C	
输出欠压保护 Output under voltage Protection	/	/	/	保护方式Protection mode: A) 恒功率Constant power; B) 恒电流Constant current; C) 输出掉电Output voltage drop;
过温保护 Over Temperature Protection	关闭输出电压 Shut down O/P voltage.	A	C	
输入过压保护 Input over-voltage Protection	持续310Vac以上可能导致损坏, 并且无法恢复; Cause damage can not be restored, if sustained 310Vac or more;	/	/	
输入欠电压保护 Brownout Protection	当输入电压低于50~60Vac以下时, 进入保护状态; 当输入电压高于65~80Vac时, 退出保护状态; Enter protection when the input voltage is below 50~60Vac; Exit protection when the input voltage is below 65~80Vac;	A	C	
其它保护	NTC热敏电阻、FUSE保险丝、Varistor压敏电阻			

Other Protection

"/": 不符合项 "/" : No function;

特殊功能 Signals Function

项目 Item	技术要求 Requirement
面板显示 Panel display	当输出指标正常时, 绿色LED常亮/Output voltage \geq 21.6V, Green LED is always on;
远程信号 Remote signal	与输出隔离, 常开触点; 当输出电压大于85%时, DC OK为低阻抗 \leq 50m Ω , 最大耐受直流30 V / 1 A/ Normally open contact, isolated output,; Output voltage \geq 85%V, DC OK is a low impedance \leq 50m Ω , Max DC 30 V / 1 A
冗余母线 Redundant bus	/
通信功能 Remote communications capability	/
电池管理功能 Battery management capability	/
其它 Other	/

"/": 不符合项 "/" : No function;

电气安全 Electrical Safety

项目 Item	测试方法 Test Method	测试条件 Test Conditions	备注 Note
高压测试 High-voltage test	输入-输出 I/P-O/P	3000Vac. 60S, \leq 15mA	
	输入-信号 I/P-Signaling	/	
	输入-大地 I/P-PE	1500Vac. 60S, \leq 15mA	
	输出-大地 O/P-PE	700VDC.60S, \leq 1mA	
	输出-信号 O/P- Singnaling	/	
绝缘阻抗 Withstand Resistance	输入-输出 I/P-O/P	500VDC. \geq 5M Ω	
	输入-大地 I/P-PE	500VDC. \geq 5M Ω	
	输出-大地 O/P-PE	500VDC. \geq 5M Ω	
泄露电流 Leakage Current	L、N-外壳/L、N-Case	3.5mA Max	
	L、N-PE/L、N-PE	3.5mA Max	
接地阻抗 PE Resistance	PE-外壳/PE-Case	< 0.1Ohm	
防爆特性 Explosion-proof	爆炸性物质分类Class I, 危险区域等级Zone 2 IECex, ATEX (Zone 2), HazLoc (Class I);	IEC60079-0/-11	
过电压等级 Overvoltage category	III, II	III (IEC 61010-1, IEC 61010-2-201, EN 62368-1, EN 61558-2-16) II (EN 62368-1, EN 60335-1)	
特低电压 ELV	SELV; PELV	EN61010-1,EN62368-1 (SELV) ; EN61010-2-201 (PELV)	
电气设备安全等级类属 Electrical equipment safety class	A	A)一类设备Class I ;B)二类设备Class II;C)三类设备 (最高标称电压不超过50Vac或120VDC, 以及不属于AB) Class III; EN 61140, GB/T17045	
安规标准 Safety	/	UL1310 (CLASS II产品)	
	/	EN62368-1, GB4943.1资讯类	
	/	EN60601-1, GB9706.1医疗类	

/	EN61347-1, EN61347-2-13, GB7000.1, GB19510.1, GB 19510.14 灯具类
	EN60335-1, EN60335-2-29, GB4706.1 家电类
	EN61010, GB4793.1 工控类

1) “/”: 不符合项 “/” Non-conformance;

2) 高压测试 high-voltage test:

2.1) 为保护用户, 电源 (因为电气部件会直接连接到潜在危险电压上) 必须遵守更严格的安全要求规定。因此, 必须确保危险输入电压和防触摸输出电压 (安全特低电压 SELV) 之间的永久安全电气隔离。为确保 AC 输入回路和 DC 输出回路之间的永久安全隔离, 作为安全认证程序 (型式试验) 和制造 (例行试验) 的一部分, 需要执行高压形式试验。In order to protect the user, power supplies (as electric components with a direct connection to potentially hazardous voltages) are subject to more stringent safety requirements. For this reason, permanent safe electrical isolation between the hazardous input voltage and the touch-proof output voltage as safety extra-low voltage (SELV) must always be ensured. In order to ensure permanent safe isolation of the AC input circuit and DC output circuit, high-voltage testing is performed as part of the safety approval process (type test) and manufacturing (routine test).

2.2) 在产品的生产制造过程中, 作为介电试验的一部分, 将根据 IEC/UL/EN 62368-1 的规定执行高压试验。高压试验将以至少 1.5kVac 或 2.2kVDC 的测试电压执行, 例行制造试验将定期接受认证机构的检验。During the manufacturing process for the power supply, a high-voltage test is performed as part of the dielectric test in accordance with the specifications of IEC/UL/EN 62368-1. The high-voltage test is performed with a test voltage of at least 1.5 kV AC / 2.2 kV DC or higher. Routine manufacturing tests are inspected regularly by a certification body

2.3) 对于大于 0.8kVac/1.1kVDC 的测试, 必须断开气体放电管的链接, 且测试电压上升和下降的斜率不低于 1 秒。For high-voltage tests > 0.8 kV AC / 1.1 kV DC, the gas-filled surge arrester must be disconnected. The test voltage should rise and fall in ramp form. The relevant rise and fall time of the ramp should be at least one seconds.

2.4) 在进行例行试验和型式试验以确保电气安全外, 最终用户不需要将电源作为单独的部件执行另外的高压试验。根据 EN 60204-1 (机械电气系统-安全需求), 在系统执行高压试验的过程中, 应断开电源的连接, 在高压试验完成后才可以重新安装。Apart from routine and type tests to guarantee electrical safety, the end user does not have to perform another high voltage test on the power supply as an individual component. According to EN 60204-1 (Safety of machinery- Electrical equipment of machines) the power supply can be disconnected during the high-voltage test and only installed once the high-voltage test has been completed.

2.5) 如果在最终检验和测试期间计划对控制柜或电源 (作为独立部件) 执行高压试验, 则必须注意以下要点。

a- 必须如接线图中所示连接电源接线。

b- 不得超过最大允许的测试电压, 避免因测试电压过高而对电源造成不必要的负载或损坏。

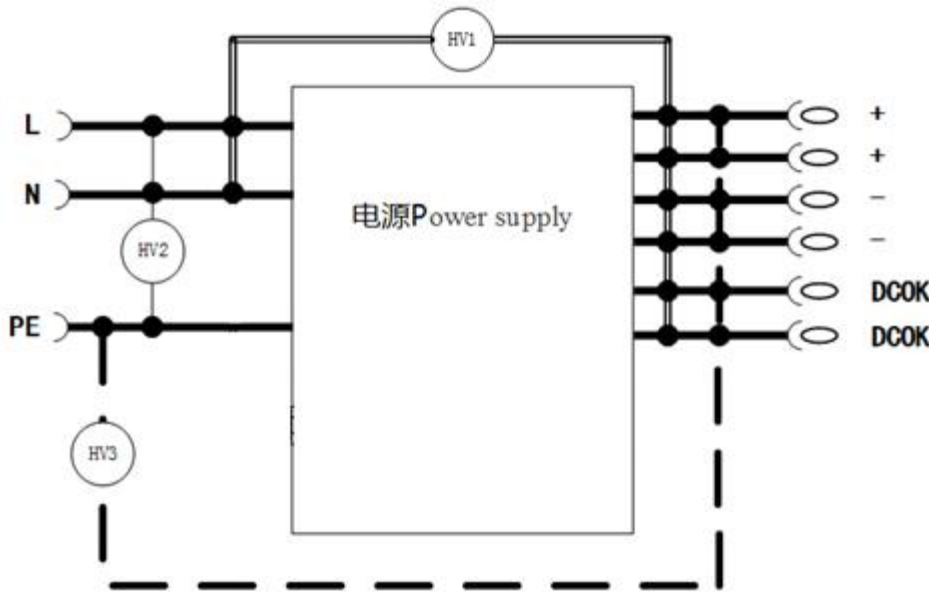

电磁兼容 Electromagnetic Compatibility

项目 Item	测试方法 Test Method	测试条件 Test Conditions
静电 ESD Electrostatic Discharge	IEC 61000-4-2 GB17626-2	Criteria A; Air Discharge: ±8kV; Contact Discharge: ±4kV
射频辐射 RS Radiated Field	IEC 61000-4-3 GB17626-3	Criteria A; 80-1000MHz, 10V/M, 80% modulation (1kHz);

脉冲杂讯EFT Electrical Fast Transient / Burst	IEC 61000-4-4 GB17626-4	Criteria A; ±4kV	
雷击 Surge	IEC 61000-4-5 GB17626-5	Criteria A; Common Mode: 4kV; Differential Mode: 2kV	
射频传导 Conducted Emission	IEC 61000-4-6 GB17626-6	Criteria A; 0.15-80MHz, 10Vrms, 80% modulation (1kHz) 80MHz-1GHz, 10Vrms, 80% modulation (1kHz) 1.4GHz-2GHz, 10Vrms, 80% modulation (1kHz) 2GHz-2.7GHz, 10Vrms, 80% modulation (1kHz)	
电源磁场 Power Frequency Magnetic Fields	IEC 61000-4-8 GB17626-8	30A/meter, Criteria B	
脉冲磁场抗扰度试验 Impulse magnetic field immunity test	IEC 61000-4-9 GB17626-9	300A/meter, Criteria B	
阻尼振荡磁场抗扰度试验 Damped oscillatory magnetic field immunity test	IEC 61000-4-10 GB17626-10	100A/meter 100KHz and 100MHz, Criteria B	
电压瞬断 Voltage Dips and Interruptions	IEC 61000-4-11 GB17626-11	Voltage Dips >95% reduction,0.5 period	Criteria A
		Voltage Dips >30% reduction,25 period	Criteria B
		Voltage interruptions >95% reduction,250 period	Criteria B
低能量脉冲 Low Energy Pulse Test (Ring Wave)	IEC 61000-4-12 GB17626-12	Criteria B Common Mode:2kV; Differential Mode: 1kV	
谐波 Harmonic Current Emission	IEC/EN 61000-3-2 GB17625-1	Class A	
电磁耐受标准 Immunity Generic Standards	/	EN 55024,GB17618资讯类	
	/	EN55014-2家电类	
	/	EN60601-1-2医疗类	
	/	EN61547灯具类	
	/	EN61000-6-1,EN50082-1,GB/T17799-1轻工业环境 EN 61000-6-2,EN55082-2,GB/T17799-2工业环境	
传导和辐射通用标准 CE&RE	/	GB9254, CISPR 32, EN 55032 : Class B 资讯类	
	/	GB4824, CISPR 11, EN 55011 : Class B 医疗类	
	/	GB17743, EN55015, CISPR15: Class B 灯具类	
	/	GB4343-1, CISPR14, EN55014-1: Class B 家电类	
	/	EN 61000-6-3, FCC Title 47, EN55011: Class B 工控类	
电压波动和闪烁 Voltage Fluctuation and Flicker		IEC/EN 61000-3-3, GB17625.2; Criteria B	

- 1) 标准A: 规格界限内正常性能Criteria A: Normal performance within the specification limits;
- 2) 标准B: 可自行恢复的临时性退化或功能丧失Criteria B: Temporary degradation or loss of function which is self-recoverable;
- 3) 标准C: 不可自行恢复的临时性退化或功能丧失, 必须重新启动后才能恢复正常工作Criteria C:Need to restart the power supply, to return to normal work;
- 4) 标准D: 永久性退化或功能丧失, 需要更换零部件或维修人员介入Criteria D:Permanent degeneration or loss of function;
- 5) 不对称: 共模 (线对地) Asymmetrical: Common mode (Line to earth);
- 6) 对称: 差模 (线对线) Symmetrical: Differential mode (Line to line);
- 7) “/”: 不符合项 “/”Non-conformance;
- 8) 电源应视为系统内元件的一部分, 需结合终端设备进行EMC确认Power should be considered part of the element within the system, to be combined with the terminal device EMC acknowledgment;

可靠性数据 Reliability

项目 Item	数据 Data	测试条件 Test Conditions
通用电源测试标准 Component Power Supply for General		EN 61204-3/-2
产品老化 Burn-in	100%	230Vac, 满载, 40°C±5°C, 4小时

平均无故障时间 MTBF	200000H Min	230Vac, 满载, 25°C, MIL HDBK 217F
-----------------	-------------	---------------------------------

“/”: 不符合项 “/” Non-conformance;

结构与安装 Mechanical Installation

项目 Item	数据 Data	备注 Note
尺寸mm (长宽高) Size	127 * 125 * 40	材质: 铝; Housing: AL
重量Kg Weight	0.74	
安装方式 Installation	导轨式安装 mounted on 35mm DIN rails	TS-35/7.5或TS-35/15 EN 60715
最小间距 Space	上下(above/below): 45mm; 左右(left and right side): 0mm, 5mm with a heat source	
输入端子 Input Terminal	脚距5.0mm, 3位 Pitch=5.0mm, 3pin	最大扭矩0.4N.M, 直插式连接, 硬导线横截面0.2 mm ² ... 4 mm ² 柔性导线横截面0.2 mm ² ... 2.5 mm ² 横截面 AWG 24 ... 12 剥线长度10 mm
	1 PIN---FG	
	2 PIN---N	
	3 PIN---L	
输出端子 Output Terminal	脚距7.5mm, 4位/Pitch=7.5mm, 4pin	最大扭矩0.4N.M, 直插式连接, 硬导线横截面0.2 mm ² ... 4 mm ² 柔性导线横截面0.2 mm ² ... 2.5 mm ² 横截面 AWG 24 ... 8 剥线长度14mm-15 mm
	1 PIN---V-	
	2 PIN---V-	
	3 PIN---V+	
	4 PIN---V+	
	5 PIN---DC OK+	
6 PIN---DC OK-		

框架图 Block diagram

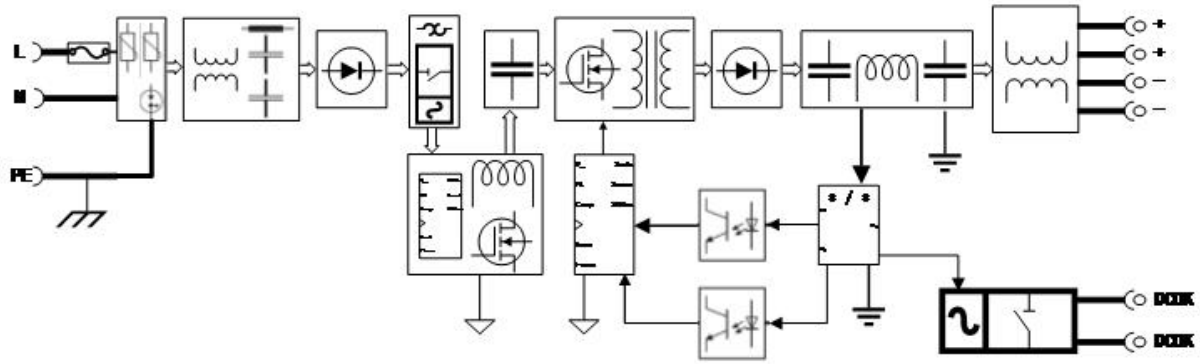

附件 (安装示意图、降额曲线、典型应用、导轨安装方法)

Appendix(Product assembly/Derating curve/Typical application/Din track mounting)

1. 产品装配示意图 Product assembly

说明:

Note:

A: 产品名称特性示意, 具体参数依照规格书。

A: Refer to product specifications.

B: 建议扭矩:M3.0螺钉<0.4 N·m; M4.0螺钉<0.6 N·m。

B:Suggested tightening torque:M3.0 screw < 0.4 N·m;M4.0 screw < 0.6 N·m



Install rail / 安装轨道: TS35/7.5 or TS35/15

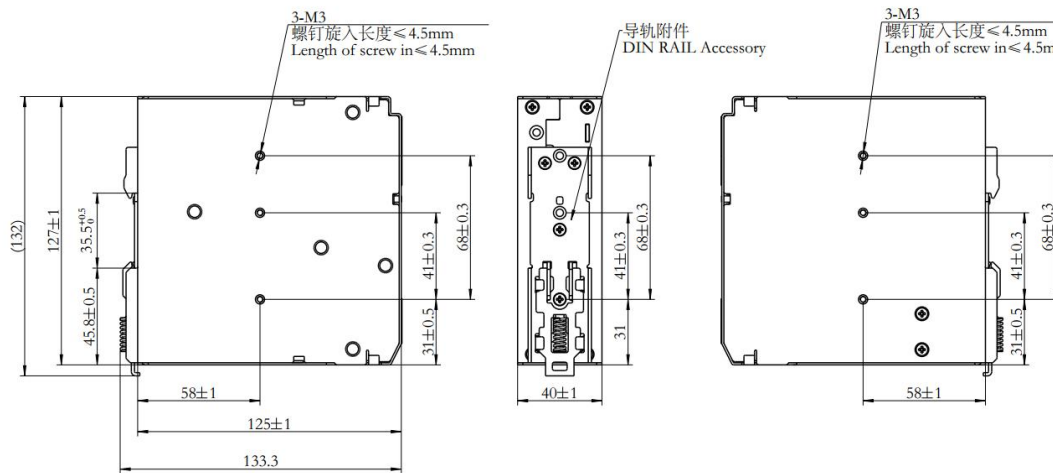

2. 降额曲线 Derating curve:



图1：输入电压下输出功率降额曲线
Fig1: Output Power Derating curve depending on Input Voltage



图2：环境温度和输入电压下输出功率降额曲线
Fig2: Output Power Derating curve depending on Ambient Temperature and Input Voltage

总输出功率的降额计算:

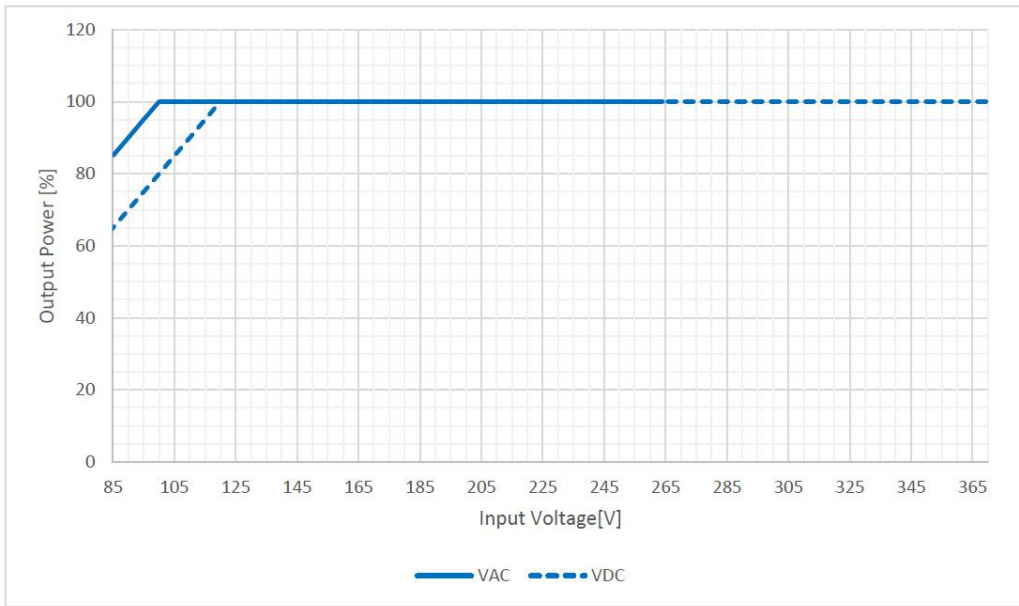
Calculation of total output power derating:

输出功率 (%) = [图1(%) × 图2(%)] / 100

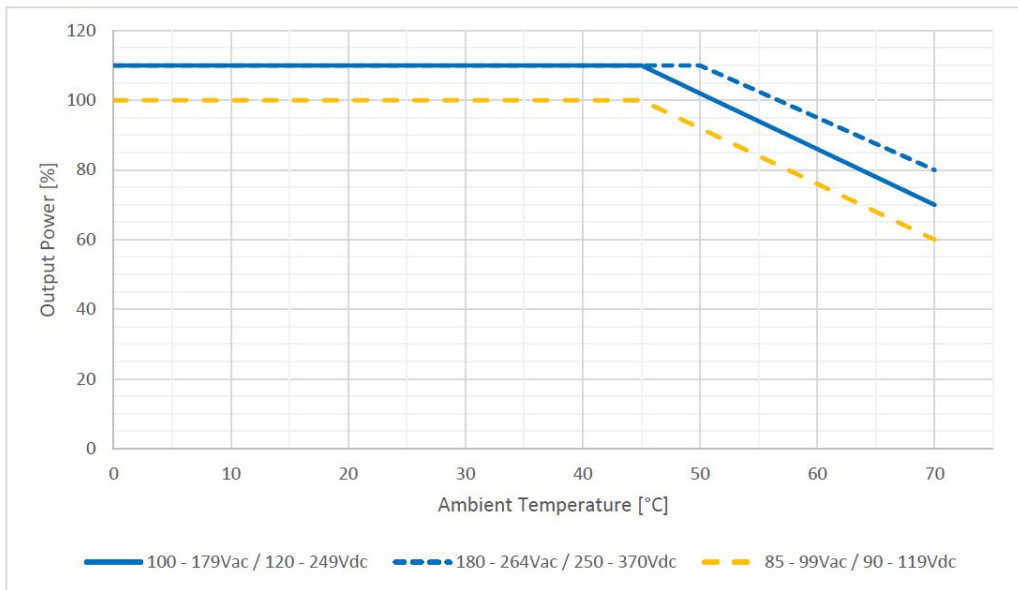
Total Output Power [%] = (Fig1 Output Power [%] * Fig2 Output Power [%]) / 100

对于图2，仅在看降额曲线时按11A输出电流，其他正常情况下按10A

For Fig2: Run 22A only when looking at the Derating curve, other normal conditions run 10A.

3. 限流特性 Current Limiting Characteristic



图1: 不同输出电压下, 正常和峰值工作时的限流曲线

Fig 1: Current limiting curve in normal and Boost operation depending on the output voltage

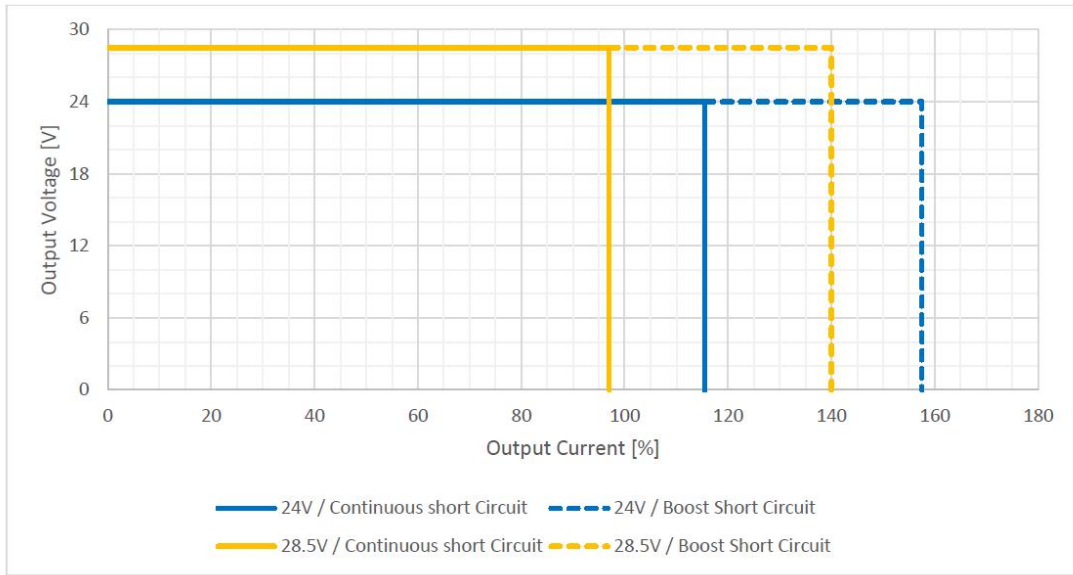

图2: 短路情况下, 非重复的峰值电流特性

Fig 2: Non-repetitive Boost during continuous short circuit

4. 峰值功率特性 Boost Characteristic

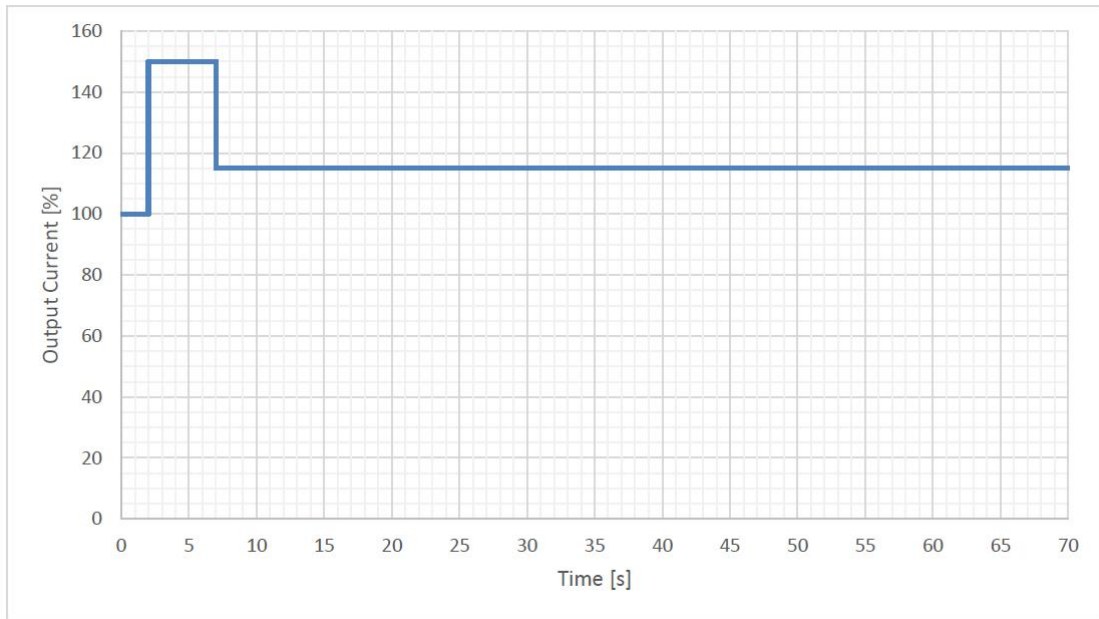

图1: 环温50℃情况下 (80%→150%输出功率) , 峰值功率时间5s

Fig 1: Timing between two Boost events for 5s at 50℃ ambient (80%→150% output power)

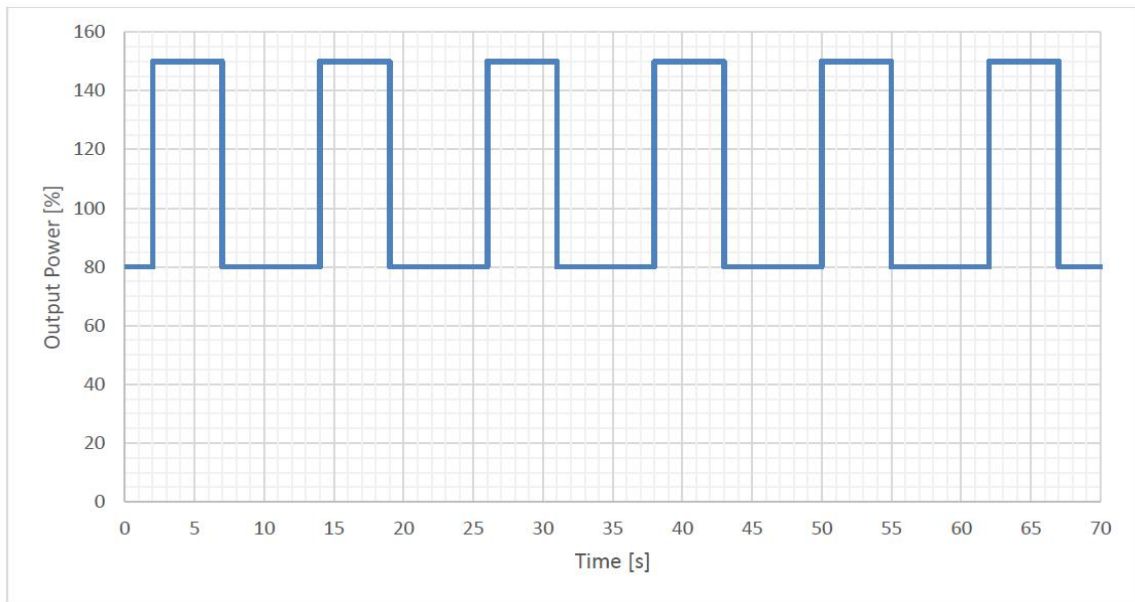

图2: 环温50℃情况下 (100%→150%输出功率) , 峰值功率时间5s

Fig 2: Timing between two Boost events for 5s at 50℃ ambient (100%→150% output power)

5. 典型应用 Typical application:

3.1 串联接线图 Series Operation Connection Diagram:

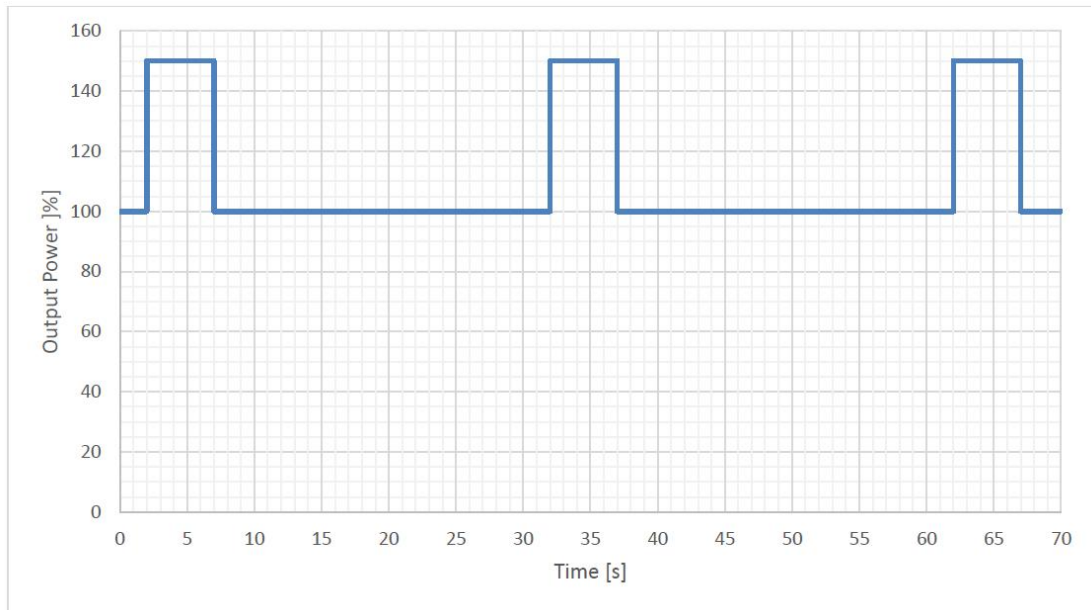
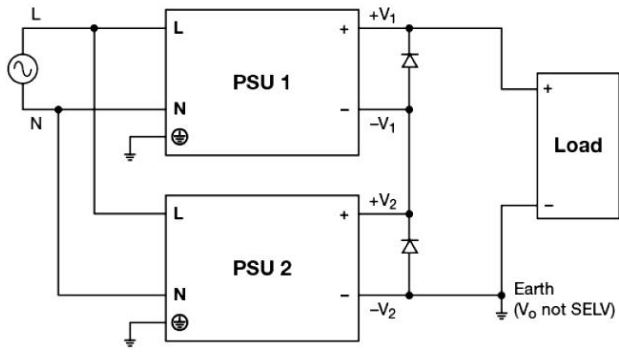

3.2 1+1 冗余接线图 1+1 Redundancy Connection Diagram

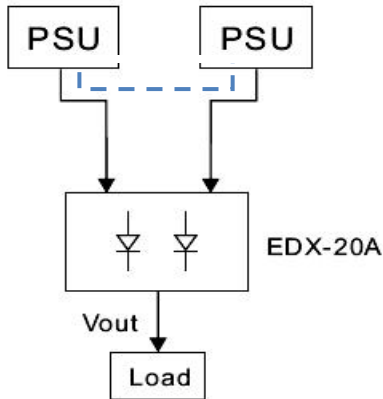

3.3 1+N 冗余接线图 1+N Redundancy Connection Diagram:

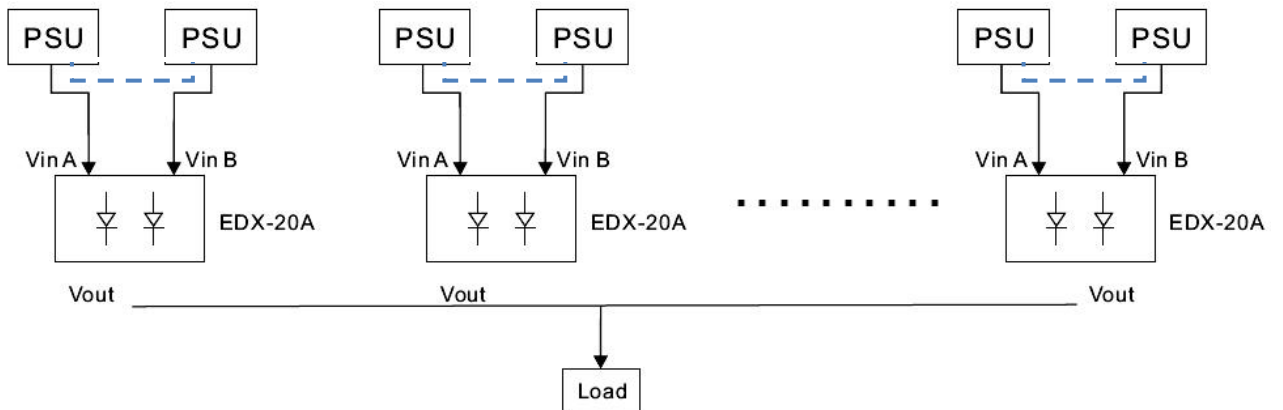

3.4 可靠性系统构建图 Reliability system:

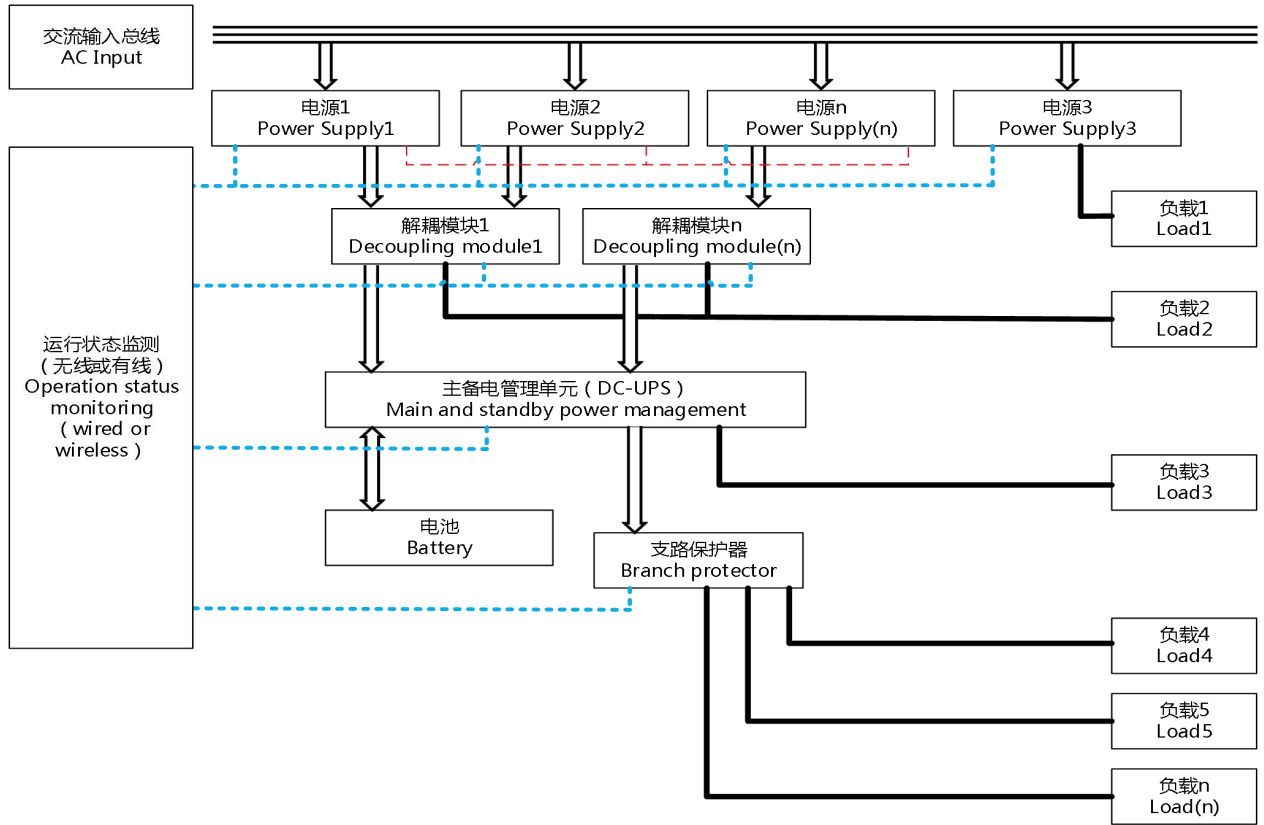

6. 导轨安装方法 Din track mounting:

- (1) To mount the Block on a DI track, hook portion (A) of the Block onto the track and press the Block in direction (B).
 安装：将(A)部分挂入导轨，朝(B)方向按压卡入导轨

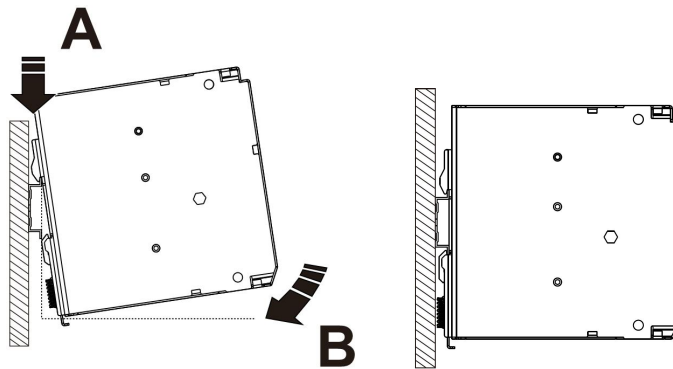

- (2) To dismount the Block, pull down portion (C) with a flat-blade screw-driver and pull out the Block.
 拆卸：用平口螺丝刀下拉(C)部分拆卸电源

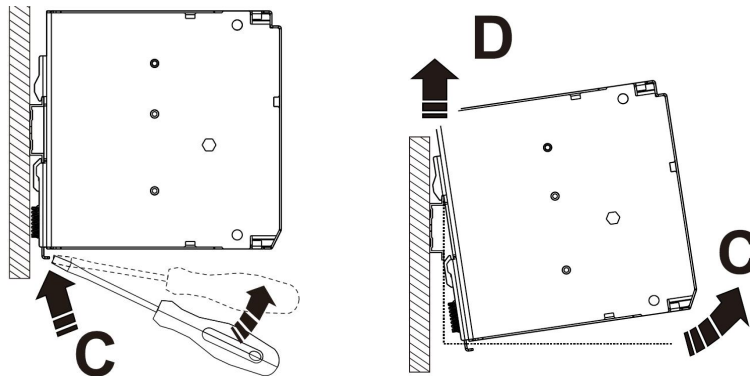

(3)通用壁挂式安装图 Mounting the universal wall adapter

